

FROM “KNIFE MEN” TO “STREAMLINING WITH CURVES”: *Structure, Skill, and Gender in British Columbia’s Meat-Packing Industry*

TIM PAULSON

FROM THE 1870S TO THE PRESENT, corporate restructuring, technological innovation, business ideology, and geography transformed meat-packing labour in North America from a pre-industrial, skilled craft into a low-paid, precarious, dangerous, and mindless “employment of last resort.”¹ In the meat industry today, transnational food chains employ temporary migrant workers at central hubs in the interior of the continent – in places such as Garden City, Kansas, and Lethbridge, Alberta – for distribution to places as diverse and distant as Montreal, Nanaimo, and Tokyo. According to many observers, the workers enter and leave with no particular meat-cutting skill that would enable them to seek better work conditions or pay.² However, in 2008, I took a job at a medium-sized meat-packing facility on Vancouver Island that, according to this narrative, should not even have existed, and the industrial meat cutters working there defied all my expectations for factory workers in the corporate food chain.

The men – and one woman – who cut up the meat exhibited many skills I thought would have been lost over a century and a half of industrial

¹ Roger Horowitz, “‘That Was a Dirty Job!’: Technology and Workplace Hazards in Meatpacking over the Long Twentieth Century,” *Labor* 5 (2008): 18. See also Lewis Corey, *Meat and Man: A Study of Monopoly, Unionism, and Food Policy* (New York: Viking, 1950), 243–74; Roger Horowitz, *Putting Meat on the American Table: Taste, Technology, Transformation* (Baltimore: Johns Hopkins University Press, 2006), 19, 153; William Cronon, *Nature’s Metropolis: Chicago and the Great West* (New York: W.W. Norton, 1991), 229–30.

² This narrative is dominant in both academic and popular journalistic accounts of the contemporary meat industry. See Eric Schlosser, *Fast Food Nation: The Dark Side of the All-American Meal* (Boston: Mariner Books/Houghton Mifflin Harcourt, 2012); Donald D. Stull and Michael J. Broadway, *Slaughterhouse Blues: The Meat and Poultry Industry in North America* (Belmont, CA: Wadsworth/Thomson Learning, 2004), 80; James Cook, “Those Simple Barefoot Boys from Iowa Beef,” *Forbes*, 22 June 1981, 34; Christopher Leonard, *The Meat Racket: The Secret Takeover of America’s Food Business* (New York: Simon and Schuster, 2014), 46, 212.

transformation. They could work with all major red-meat species, from cattle to deer, and they could butcher whole animals, if necessary, right down to the testicles. The workers included immigrants and locals, who between them offered several lifetimes of experience cutting meat. Most shocking of all to me was the fact that they called themselves “butchers,” a term that I thought was reserved for the owners of specialty shops located downtown. Why did these workers in British Columbia not conform to historians’, journalists’, and other experts’ understanding of meat-packing labour in the twentieth and twenty-first centuries, and what did that say about the place of British Columbia in a transnational narrative of industrial decline?

Historically, British Columbia’s regional meat-packing industry remained an outlier and was resistant to dominant trends in Canada and the United States that led to production being concentrated into massive, semi-automated production plants.³ Fewer transnational firms and fewer machines meant that workers in British Columbia retained skills that became obsolete throughout most of the industry. According to labour theorists, “skill” may be defined as having physical and mental control over one’s work, and it is both a real need and a discourse that affects the balance of power between workers, management, and technology. Workers in British Columbia charted out a middle ground between older craft-oriented labour structures and newer industrial ones, and this enabled them to continue leveraging their skills to achieve not only practical gains vis-à-vis management but also personal pride and happiness. This places them in strong contrast with the workers who populated degraded workplaces elsewhere in North America.

Although the West Coast was not fully subject to the larger structures shaping the political economy of meat-packing, it was not completely isolated from them either. Skilled male workers in British Columbia resisted the deskilling tendencies of corporate capitalism in part by deflecting them onto a growing female workforce. When large, automated machines did appear in BC meat-packing facilities, women operated them, and they bore the consequences of this in their paycheques and on their bodies. The working man’s culture of craft and skill could be a tool for working-class power, but it also imported many of the prejudices

³ British Columbia was “exceptional” in its own way, but it is also true that most regions diverge in some way from national and transnational trends in capitalism. The results may therefore be generalized as a way of thinking about how things look different at different scales. See the literature on “varieties of capitalism,” including Peter A. Hall and David Soskice, eds., *Varieties of Capitalism: The Institutional Foundations of Comparative Advantage* (New York: Oxford University Press, 2001).

of working men's masculinity into the modern plants. In fact, "skill" served men best in a strictly superficial sense by rendering "deskilling" feminine and therefore invisible. The discourse of "skill" relied on, and ultimately reinforced, gender segregation in the workplace, which prevented the wider solidarity needed to enable the working class as a whole to achieve deeper and more permanent gains throughout British Columbia and across North America.⁴

STRUCTURE VERSUS SKILL IN THE POLITICAL ECONOMY OF MEAT-PACKING

In the 1880s, when meat processing in British Columbia still consisted of a narrow network of butchers and abattoirs located in wooden shacks that barely spanned the province, an industrial revolution in meat-packing was in full swing in eastern North America. Following the lead of Gustavus Swift, a small cadre of American industrialists constructed a large-scale meat-packing hub in Chicago to slaughter, process, and deliver meat (especially beef) to growing urban markets in the east. They built factories of unprecedented size and reorganized the slaughtering process into discrete parts performed by different workers on what they called the "disassembly line." The Chicago packinghouses became a template for other industrialists even as they became notorious for horrible labour conditions. In an infamous exposé of labour conditions in the packinghouses, journalist Upton Sinclair observed: "It was all so very businesslike that one watched it fascinated. It was pork-making by machinery, pork-making by applied mathematics ... [B]ut this slaughtering machine ran on."⁵ Sinclair was not discussing iron machinery but, rather, the way that people functioned within a larger industrial process – a process that they neither controlled nor understood and within which they could be likened to cogs in a machine. Canada followed a similar course of modernizing and concentrating production, first in southern Ontario and later in Alberta. By the 1920s, Canada Packers, Swift

⁴ Scholars of the American meat-packing industry argue that, at different times, ethnic and racial cooperation or conflict underwrote the strength or weakness of the labour movement. This case demonstrates that gender is also a crucial variable for labour power in meat-packing. See Roger Horowitz, *"Negro and White, Unite and Fight!": A Social History of Industrial Unionism in Meatpacking, 1930-90* (Urbana: University of Illinois Press, 1997); Rick Halpern, *Down on the Killing Floor: Black and White Workers in Chicago's Packinghouses, 1904-54* (Urbana: University of Illinois Press, 1997).

⁵ Upton Sinclair, *The Jungle* (New York: Signet Classics, 1980), 39-40.

Canadian, and Burns formed the “big three,” which could be compared to the American “big four” corporations.⁶

The era of corporate concentration in the east created some of the most horrendous working conditions the meat-packing industry had ever seen, but it did not eliminate the skilled labour of butchering and slaughtering. Rather, it created a hierarchy, which economist John R. Commons described in 1904:

Yet, notwithstanding the high skill required, the proportion of skilled workmen in the butchers' gang is very small, owing to a minute division of labor. It would be difficult to find another industry where division of labor has been so ingeniously and microscopically worked out. The animal has been surveyed and laid off like a map; and the men have been classified in over thirty specialties and twenty rates of pay, from 16 cents to 50 cents an hour ... Skill has become specialized to fit the anatomy.⁷

Commons goes on to describe nine different positions whose purpose was just to strip off the hide, and he describes how the higher-paid skilled workers were confined to very specific tasks, while lower-paid workers performed the rest. Sociologist Harry Braverman theorizes that the division of labour in meat-packing stemmed from capitalism's tendency to limit workers' power through “deskilling”; still, from the 1920s to the 1940s, workers in the industry managed to organize strong unions and to fight for remarkable gains in pay and workplace safety.⁸

⁶ Canada Packers formed in 1927 when the Harris Abattoir Company merged with four other Ontario packers, and Swift Canadian was a branch of a major American packing company based in Chicago since the 1870s. Pat Burns founded P. Burns and Co. in 1890. Burns was the first of the national packers to operate major production in the west, and he was responsible for the later centralization of the industry in Alberta. See David Ll. Davies, “Meat Packers/ Abattoirs in Greater Vancouver, 1900-1999,” City of Vancouver Archives (hereafter CVA), David Ll. Davies Collection, Add. MSS. 1444-28, 2006; C. Rhodes Smith, Pierre Carignan, and A.S. Whiteley, *Report Concerning the Meat Packing Industry and the Acquisition of Wilsil Limited and Calgary Packers Limited by Canada Packers Limited: Combines Investigation Act* (Ottawa: Restrictive Trade Practices Commission, 1961), 70-77; James Rennie, ed., *The Growth and Development of Canada's Meat Packing Industry* (Islington, ON: Meat Packer's Council of Canada, 1969), 46; Canada Packers Limited, *The Story of Our Products: Canada Packers Limited, Toronto, Montreal, Hull, Peterborough, St. Boniface, Edmonton and Vancouver* (Kingston, ON: Jackson Press, 1943), 41; Cynthia Loch-Drake, “‘A Special Breed’: Packing Men and the Class and Racial Politics of Manly Discourses in Post-1945 Edmonton, Alberta,” *Atlantis* 32 (2007): 135; Ian MacLachlan, *Kill and Chill: Restructuring Canada's Beef Commodity Chain* (Toronto: University of Toronto Press, 2001), 123-60, 185-213.

⁷ John R. Commons, “Labor Conditions in Meat Packing and the Recent Strike,” *Quarterly Journal of Economics* 19 (November 1904): 3-4. See also Lewis Corey, *Meat and Man: A Study of Monopoly, Unionism, and Food Policy* (New York: Viking, 1950), 251.

⁸ On deskilling, see Harry Braverman, *Labor and Monopoly Capital: The Degradation of Work in the Twentieth Century*, 25th anniversary ed. (New York: Monthly Review Press, 1998), 4, 6,

In Canada and the United States, the emblem of organized labour's success in meat-packing was a standardized collective bargaining system known as "the master contract," and it paid some of the highest wages in industrial manufacturing.

Starting in the 1950s, mechanization ignited a second industrial transformation in meat-packing.⁹ The revolution began outside Winnipeg in 1951, when Canada Packers' St. Boniface plant introduced the first continuous overhead rail dressing technology, which was briefly called the "Can-Pak" system. According to geographer Ian MacLachlan, Can-Pak could speed up beef killing to two times the previous output so long as the facility was big enough, and it became standard across Canada and the United States.¹⁰ Can-Pak made beef killing easier and safer for workers, but its goal was profit, and subsequent machines in the revolution sought profit even to the detriment of workers' well-being.

According to Harry Braverman – whose work on capitalism's effect on the labour process is still the best and most controversial – machines were a particularly insidious tool for implementing the dual mantra of efficiency and class domination. As he explains, "the more science is incorporated into the labor process, the less the worker understands of the process; the more sophisticated an intellectual product the machine becomes, the less control and comprehension of the machine the worker has." Consequently, the more complex machines and machine-systems of the mid-twentieth century enabled highly skilled specialists from the management class to dominate workers. Paradoxically, in the labour

35-40, 51, 86, 295. Two unions organized butchers and meat-packing workers – the Amalgamated Meat Cutters and Butcher Workmen of North America (AFL), starting in the 1890s, and the United Packinghouse Workers of America (CIO) in the 1940s. See Stull and Broadway, *Slaughterhouse Blues*, 69; Corey, *Meat and Man*, 34, 61, 298.

⁹ Michael J. Broadway, "Where's the Beef? The Integration of the Canadian and American Beefpacking Industries," *Prairie Forum* 23 (1998): 20; Horowitz, "That Was a Dirty Job," 16; Horowitz, *Putting Meat on the American Table*, 19; Jimmy M. Skaggs, *Prime Cut: Livestock Raising and Meat Packing in the United States, 1607-1983* (College Station: Texas A&M University Press, 1986): 200; Stull and Broadway, *Slaughterhouse Blues*, xiii, 72-73; Alain Noel and Keith Gardner, "The Gainers Strike: Capitalist Offensive, Militancy, and the Politics of Industrial Relations in Canada," *Studies in Political Economy* 31 (Spring 1990): 31-32; David Bright, "Meatpackers' Strike at Calgary, 1920," *Alberta History* 44 (Spring 1996): 2, 6; Corey, *Meat and Man*, 10-11; Anne Forrest, "The Rise and Fall of National Bargaining in the Canadian Meat-Packing Industry," *Relations industrielles/Industrial Relations* 44 (1989): 394; Bruce Fehn, "Ruin or Renewal: The United Packinghouse Workers of America and the 1948 Meatpacking Strike in Iowa," *Annals of Iowa* 56 (1997): 349-51; Gregory S. Kealey, "1919: The Canadian Labour Revolt," in *The Character of Class Struggle: Essays in Canadian Working Class History, 1850-1985*, ed. Bryan D. Palmer (Toronto: McClelland and Stewart, 1986), 98.

¹⁰ MacLachlan, *Kill and Chill*, 171-75.

June 2, 1953

L. T. FORCE ET AL

2,640,225

PROCESS FOR DRESSING BEEF CATTLE AND THE LIKE

Filed April 24, 1951

3 Sheets-Sheet 2

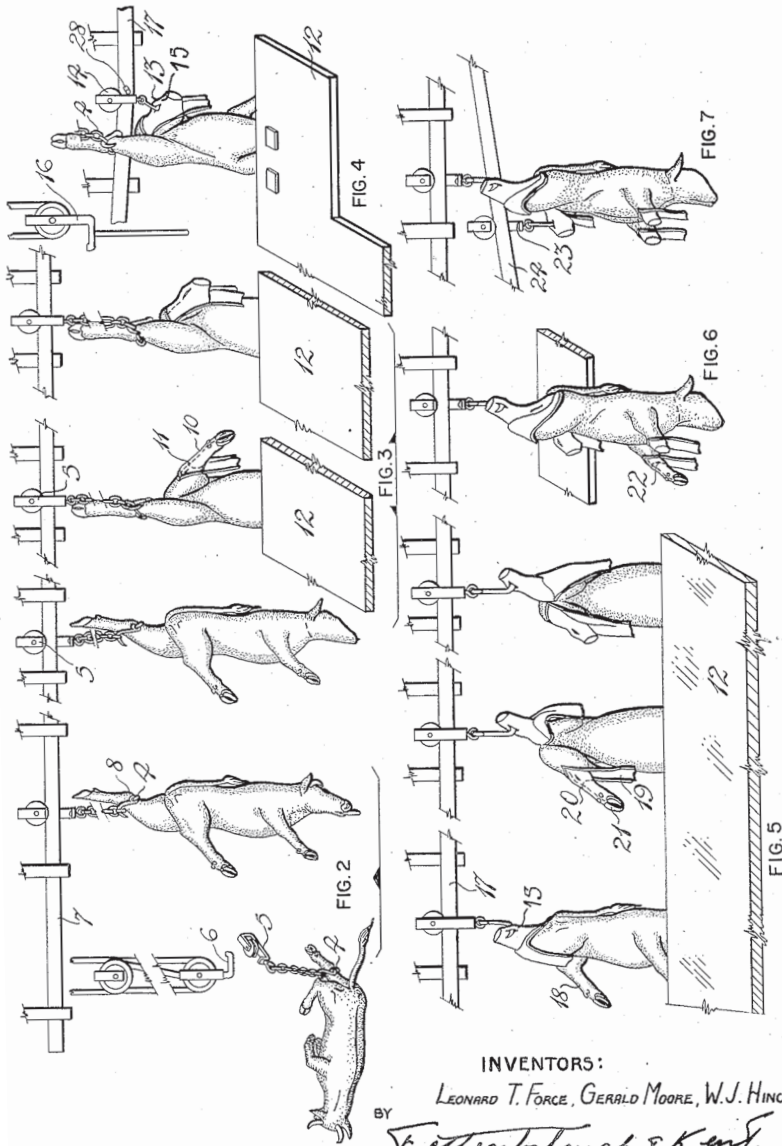

INVENTORS:

LEONARD T. FORCE, GERALD MOORE, W.J. HINCKS

BY *Frithson, Lamberton & Kent*
Their Attys

Figure 1. Patent drawings from the "Can-Pak" system invented in 1951 by Canada Packers, a Canadian firm that led the continent in the semi-automated mechanization of meat-packing. Leonard T. Force, Gerald Moore, and William J. Hinks, inventors, "Process for dressing beef cattle and the like," US Patent 2640225 A, filed 24 April 1951, published 2 June 1953, original assignee Canada Packers, Ltd.;

July 17, 1956

M. FILL ET AL

2,754,767

MARSHALLING AREA CONTROL ASSEMBLIES

Filed Nov. 16, 1951

2 Sheets-Sheet 1

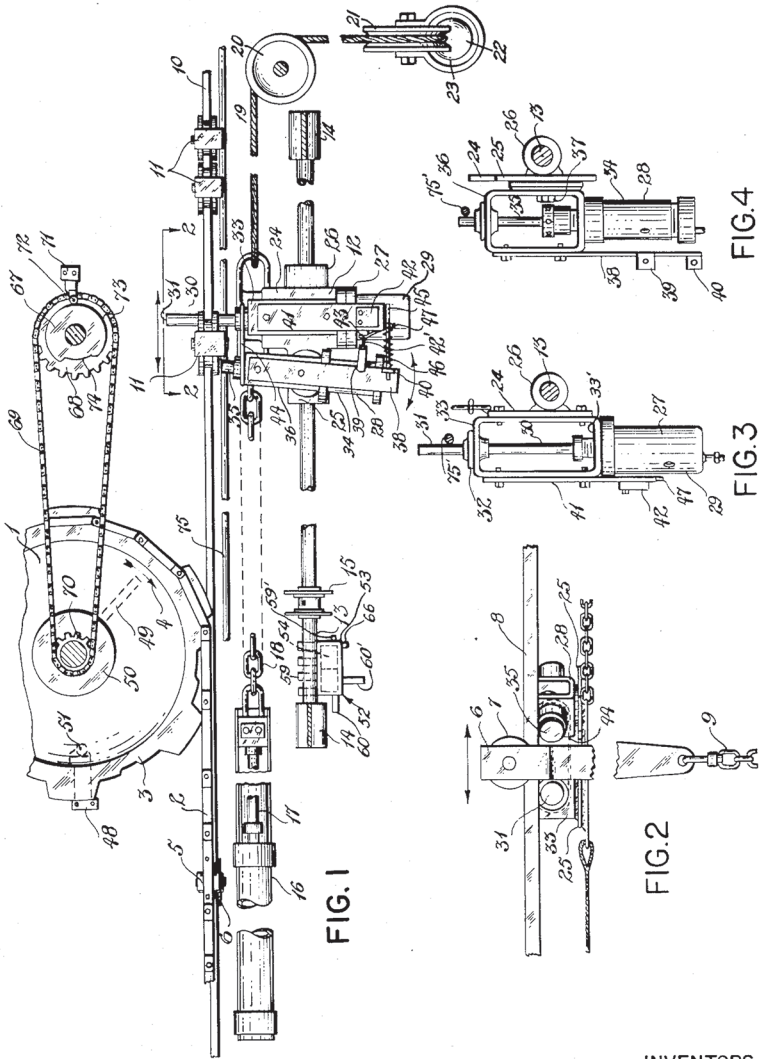

INVENTORS
 METRO FILL,
 JOHN E. GRAVER
 BY *Federstaedt & Heid.*
 ATTORNEYS

Metro Fill and John E. Graver, inventors, "Marshalling area control assemblies," US Patent 2754767 A, filed 16 November 1951, published 17 July 1956, Original Assignee Canada Packers, Ltd.

process, “the more there is to know the less the worker needs know,” and, indeed, the less the worker *could* know.¹¹

Braverman peddles in abstract ideal types, but the mechanization of meat-packing in the 1950s and 1960s did lead to the very real *re-degradation* of labour across North America in the 1970s and 1980s.¹² Machines thoroughly transformed the killing and processing of animals, and new corporations reversed the gains of labour and recreated a meat trust in the interior west even greater than that of Chicago. In large meat-packing plants, injury and turnover rates increased, while wages decreased.¹³ Furthermore, mechanization at large plants enabled meat-packing firms to deskill labour across an even wider number of small and medium-sized regional facilities through the distribution and marketing innovation known as “boxed beef.” Boxed beef programs originated in the United States but spread to large Canadian plants by the 1970s. Large, concentrated packers used their machine advantage to produce and sell boxes of beef cuts (such as shoulders, rumps, tenderloins, and, later, even steaks) to local retailers for lower costs than could be offered by skilled butchers.¹⁴ Butchering became the much more narrow and less

¹¹ Braverman, *Labor and Monopoly Capital*, 49–51, 56–57, 295, 304–5. Note that Braverman argues that the alleged upskilling of labour in the twentieth century indicated by the American census was simply a change in vocabulary. He maintains that the so-called semi-skilled machine operators were actually less skilled than were the “unskilled workers” of previous generations. See Braverman, *Labor and Monopoly Capital*, 297–301.

¹² Braverman provides a useful and coherent model of what industrialization and deskilling look like under straightforward Marxist principles. The model is unique in that it emphasizes ongoing capitalist ideology (the attempt to control workers) over contingent market forces (i.e., organized labour failed because capitalist profitability declined). The model’s main flaw is that it fails to adequately theorize worker resistance or the sources of working-class consciousness. The model is useful in studies that focus on things Braverman overlooked, like this one on gender, because it provides a baseline that enables us to identify when different variables became determinative. Please see the critical literature on Braverman’s *Labor and Monopoly Capital*, including Rick Baldoz, Charles Koeber, and Philip Kraft, eds., *The Critical Study of Work: Labor, Technology and Global Production* (Philadelphia: Temple University Press, 2001); Thomas L. Steiger and Mark Wardell, “The Labor Reserve and the Skill Debate,” *Sociological Quarterly* 33 (1992): 413–33; Jackie West, “Gender and the Labour Process: A Reassessment,” in *Labour Process Theory*, ed. David Knights and Hugh Willmott, 244–73 (London: Macmillan, 1990); Anne Phillips and Barbara Taylor, “Sex and Skill: Notes toward a Feminist Economics,” *Feminist Review* 6 (1980): 79–88; Sheila Cohen, “A Labour Process to Nowhere?” *New Left Review* 165 (1987): 34–50.

¹³ Deborah Fink, “Farm Boys Don’t Believe in Radicals’: Rural Time and Meatpacking Workers,” in *Food in the USA: A Reader*, ed. Carole M. Counihan (New York: Routledge, 2002), 144; Cook, “Those Simple Barefoot Boys,” 35–36; Broadway, “Where’s the Beef?,” 21, 27; Stull and Broadway, *Slaughterhouse Blues*, 73; Noel and Gardner, “Gainers Strike,” 32–34; Horowitz, “That Was a Dirty Job,” 16.

¹⁴ Joel Novak, “Peripheralizing Core Labour Markets? The Case of the Canadian Meat Packing Industry,” *Work Employment Society* 3 (1989): 158–59. Cook, “Those Simple Barefoot Boys,” 36; Select Standing Committee on Agriculture (hereafter SSCA), *British Columbia Meat Packing*

skilled job of portioning a clean tenderloin into filets. Boxed beef was a distribution technology, not a machine per se, but it was the strongest and most subtle technology associated with the mechanized revolution in meat-packing.

The history of the largest meat-packing plants, from Chicago and Toronto to Garden City and Lethbridge, offers an archetype for understanding the North American meat-packing industry as a whole. This makes sense not only because these facilities controlled such a large percentage of the market but also because they tended to render regional facilities obsolete and their histories moot. In this narrative, the structures of industrial meat-packing (including geographies of capital, scientific management of the labour process, and machines) broke the skills needed to butcher animals and reduced workers' power in the industry several times over. However, the multiple waves of industrial concentration never eliminated the business in British Columbia, and workers resisted transnational "deskilling" forces.

BUTCHERS AND MEAT PACKERS IN BRITISH COLUMBIA

British Columbia, on the west side of the Rocky Mountains, developed an independent meat-packing industry in the late nineteenth century. A man named Jacob John Grauer, who came to British Columbia from Seattle in the 1880s, became the first true meat packer in the province. He set up a three-room shack slaughterhouse and butcher shop on 7th Avenue in the Mount Pleasant area of Vancouver, and later moved his growing operation to Richmond. Grauer's business thrived, and he purchased his own cattle ranches in addition to the animals he bought from around the province and the United States. Grauer's business was fully vertically integrated, and he extended his sales to a widening group of meat markets. He operated one of the largest meat-processing businesses in British Columbia before the national packers opened branches in the province. Grauer's business was relatively small, and British Columbia basically missed the worst of the "meat trust" era from 1870 to 1905.¹⁵

When large national companies began expanding into British Columbia during the first half of the twentieth century, they encountered elements of a modern industry alongside older craftwork operations. Grauer's business was more integrated on the supply, or backwards, side

Industry: A General Overview – Phase III Research Report (Victoria, BC: SSCA, 1977), 11; Norm Watling, oral history interview with author, Victoria, BC, 11 March 2010.

¹⁵ Rudolph Martin Grauer interview, British Columbia Archives (hereafter BCA), Imbert Orchard Records (hereafter IOR), T0446:0001, 1964.

than the “big” packers ever were, but smaller abattoirs and butchers still served local populations all over the province.¹⁶ Rather than just wiping local production out, as was the model elsewhere, the new companies built on the structures that Grauer and other butchers had established. The industry concentrated close to the urban hub of Vancouver, and a few large firms operated at the centre of a network of mid- and small-sized processing facilities. Pat Burns became the first of the big three west of the Rockies when, around the turn of the century, he bought out Grauer and set up meat markets all over the province. According to Charles Sutcliffe, who worked for Burns in British Columbia until 1915, “he was one of the biggest men in Canada at one time,” and “he had a butcher shop in every place from Alberta to the coast where there was enough business to keep one man and a few dollars for him.”¹⁷ Initially, Burns did not try to replace the craft butchers with centralized industrial packing; rather, he just wanted to own them. Burns subsequently built a modern packing plant in Vancouver in 1906, but he continued to operate small retail meat markets around the province. Soon after, Swift Canadian acquired its Vancouver plant in 1919, and Canada Packers built its plant in 1938. By the 1940s, if not sooner, all three national companies had branch distributors in Victoria and other cities.¹⁸

Economies of scale drove the concentration of production in Vancouver during the big three packers era. The idea in British Columbia was the same as elsewhere: to maximize output from a single facility so that it became feasible to market “waste products” for a profit – but on a regional scale that belied that same logic on a national or a continental scale.¹⁹ Railway historian David L. Davies determines that, from 1891 to 1971, the beef stock available in British Columbia for local slaughter to meet the

¹⁶ The Canadian “big three” and American “big four” packers focused more on forward integration into distribution and retailing, and both came under anti-trust regulations to limit vertical integration (in 1923 by the Combines Investigation Act and in 1921 by the Packers and Stockyards Act) before they achieved significant integration of cattle sources. See Smith et al., *Report Concerning the Meat Packing Industry*; Mary Yeager, *Competition and Regulation: The Development of Oligopoly in the Meat Packing Industry* (Greenwich, CT: Jai Press, 1981).

¹⁷ Charles and Christine Sutcliffe interview, BCA, IOR, T0913:0001, 1965.

¹⁸ Robert Doherty interview, BCA, IOR, T2749:0001, ca. 1960s; Hubert Smith, oral history interview with author, Victoria, BC, 11 January 2010; Lloyd Stevenson, oral history interview with author, Victoria, BC, 28 December 2009; James B. Wells, oral history interview with author, New Westminster, BC, 6 February 2010; Smith et al., *Report Concerning the Meat Packing Industry*, 70–77; see also Jim Silver, “The Origins of Winnipeg’s Packinghouse Industry: Transitions from Trade to Manufacture,” *Prairie Forum* 19 (1994): 16.

¹⁹ The meat packers’ pursuit of economies of scale led to the myth that they sold “everything but the squeal.” See Stull and Broadway, *Slaughterhouse Blues*, 3; Cook, “Those Simple Barefoot Boys,” 34; *Burns Shamrock News*, August 1958, Legislative Library of British Columbia (hereafter LLBC).

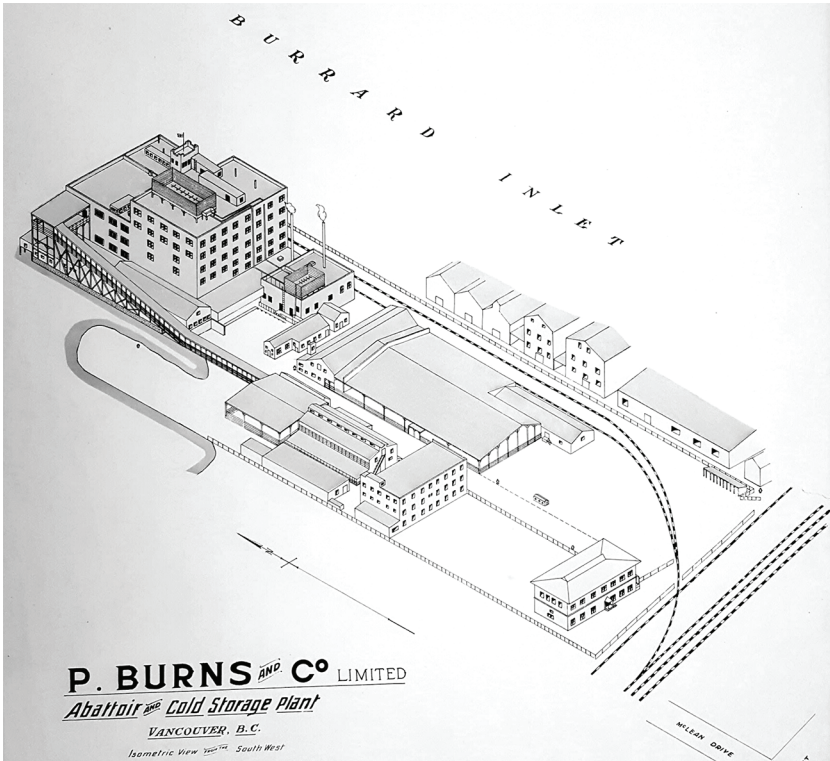

Figure 2. Burns' seven-story packing plant in Vancouver, 1925. Cattle walked up the ramp (in the left foreground) to the kill floor, and the meat passed across each story and downwards as it was processed. "P. Burns and Co. Abattoir and Cold Storage Plant," in "Fire Insurance Plan of City of Vancouver Harbour, British Columbia, Compiled and Published by Plan Dept., British Columbia Fire Underwriters Association, June 1925," University of British Columbia Rare Books and Special Collections.

population's demand decreased from 111 percent to 49 percent, but that this represented absolute growth from 27,250 to 137,000 animals.²⁰ Thus, at one and the same time, it could be true that Alberta was eclipsing the local BC industry and that the local BC industry was growing at a healthy rate.

In Canada as a whole, by the second half of the twentieth century, the three major national packing companies controlled over half of the market; however, in British Columbia the national packing companies had smaller plants and lower sales. Consistent employment records for facilities in the BC meat industry are sparse, but data collected during

²⁰ David L.I. Davies "Moving Livestock by Rail: An Inquiry into an Extinct Traffic," *Sandhouse* 31, 1 (2006): 6-21; Preparatory notes (in author's possession) for previous article.

government investigations of concentration in Canadian meat-packing suggest that the national packers never achieved the same levels of concentration in British Columbia as they did elsewhere. Cold storage, or refrigerator, space serves as a proxy for market power since, for a modern meat-packing plant, refrigeration was among the most essential capital investments. Canada Packers, for example, controlled 10.7 percent of all cold storage available for all industries in Ontario and 3.8 percent in Alberta but only 1.5 percent in British Columbia.²¹

Existing data also reveal that meat-packing labour in British Columbia was more evenly distributed across facilities in the second half of the twentieth century, and the BC industry actually became less concentrated between 1950 and 1980.²² Strike and lockout data provide insight into the relative size of the national packers' facilities across Canada. In 1966, during a national strike at Canada Packers, 244 employees struck in Vancouver, while 925 struck in Winnipeg and 805 in Calgary and Edmonton. Again in 1978, 180 people went on strike in Vancouver while 800 struck in Winnipeg and 680 in Edmonton.²³ Vancouver never even showed up in the federal Department of Labour Strike and Lockout Tables for national strikes at Burns and Swifts, probably because, after 1969, these tables did not report disputes involving fewer than one hundred people.

The BC workplace never experienced the level of mechanization that modern technology had made possible at this time. For example, Burns Vancouver's employee newsletter (*Spork Plugs* and, later, *Burns Shamrock News*) reported on some new technology at the company's Vancouver plant, but this never compared to the technology upgrades occurring concurrently in Regina, Kitchener, Calgary, and Prince Albert.²⁴ In fact, Intercontinental was the only major facility in Vancouver to introduce and maintain modern equipment. In part, British Columbia experienced relatively low mechanization because the new machines represented a

²¹ Smith et al., *Report Concerning the Meat Packing Industry*, 223.

²² Standing Senate Committee on Agriculture, *Industry in Turmoil: Report on the Long-Term Stabilization of the Beef Industry in Canada* (Ottawa: Standing Senate Committee on Agriculture, 1982), 21; Smith et al., *Report Concerning the Meat Packing Industry*, 93; R.W. Bonner and T.L. Sturgess *The Meat Industry in British Columbia* (restricted), LLBC, Bureau of Economics and Statistics, Department of Industrial Development, Trade, and Commerce, Victoria, BC, November 1961; SSCA, *British Columbia Meat Packing Industry*. SSCA, *The Meat Processing Industry in British Columbia: Phase III Research Report* (Richmond, BC: SSCA, 1978).

²³ *Strikes and Lockouts in Canada, 1947-85* (Ottawa, ON: Labour Canada, 1948-74).

²⁴ See, for example, Regina's new smokehouse, Prince Albert's new plant, and Winnipeg's new beef and veal lines in LLBC, *Spork Plugs/Burns Shamrock News*, June 1956, October 1956, April 1957, and December 1957, respectively.

serious capital investment. The major national packers did not see opportunities for growth in British Columbia, so they focused on other facilities.

Essentially, the BC market did not warrant the three main national packers. Unlike in Alberta, meat processing in British Columbia developed close to urban centres, so the optimum size of facilities actually decreased.²⁵ Beef (even if grown in British Columbia) increasingly came dressed and, later, *boxed* from Alberta. This is because most cattle were finished in Alberta feedlots, and rail rates and technologies made it less expensive to ship dead animals than live ones. The completion of the Rogers Pass Highway 1 in 1962 helped to further break the barrier that the Rocky Mountains posed for shipping goods and people. In fact, all three of the original national packers shut down their slaughter facilities entirely in the 1970s. These companies only maintained operation in British Columbia to compete with each other, and the exclusively local market meant that each company had to operate at much lower levels in this province than elsewhere.²⁶

In the 1970s, British Columbia returned to the autonomous competitor situation created by Grauer at the turn of the century. In 1964, Intercontinental Packers Ltd. bought out Pacific Meats, a local company, and it took over most of the business from the departing major packers.²⁷ According to Jim Wells, a former employee, "Intercontinental Packers had more than two-dozen routes throughout the lower mainland going all the way out to Chilliwack and down to Seattle and over to Victoria." "Intercon" Vancouver, which slaughtered and processed cattle and hogs, was three stories high, ran a whole city block in length, and occupied four hectares. The plant employed between 370 and 429 people with a payroll of \$10 million. Wells later worked for the union (originally the Packinghouse Workers of America, it would later become the United Food and Commercial Workers) in the 1970s and 1980s, and, by that time, Intercon controlled 27 percent of the province's meat-packing

²⁵ Alberta's industry was raw materials-oriented, like the major meat-packing plants in the United States. British Columbia's industry was still market-oriented, giving it a much smaller potential distribution area. British Columbia's plants probably never made the shift towards rural locations after 1950 because the province did not grow enough feed grain. See Donald Ross Staley, "The Beef Packing Industry in British Columbia" (BA essay, Commerce 490, 1965), 22, in University of British Columbia Library Rare Books and Special Collections (hereafter UBC Special Collections).

²⁶ H. Bruce Huff and Barry D. Mehr, *Developments in Central Processing of Beef in Canada* (Ottawa: Commission of Inquiry into the Marketing of Beef and Veal, 1976), 1; *BC Beef Industry Seminar Proceedings* (Richmond, BC: Beef Industry Development Committee, 1977), 58; SSCA, *British Columbia Meat Packing Industry*, 16-17.

²⁷ Intercontinental was a Saskatoon-based company. It closed its Vancouver plant in 1997.

business. Intercontinental became a rare competitor of the centralized big three, with control of a significant peripheral market. By the 1970s, Intercontinental was the only national slaughterer in British Columbia, and the firm shared the Canada Packers-Swift-Burns void with many mid-sized companies.²⁸

Privately owned local companies were very strong in this province. Even though British Columbia and Alberta employed roughly the same number of meat-processing workers and the former had significantly smaller federal plants, the mean employees per plant was higher in British Columbia. This was because employment in Alberta was polarized between massive and small facilities, while, in BC, employment was more evenly distributed across mid-sized industrial facilities. Pacific Meats, Meteor Meats, Vancouver Fancy Sausage, and Fletchers were all important mid-sized processors based in British Columbia. In this province, the private local companies put a greater amount of capital investment into their facilities, and (with the exception of Intercontinental Packers) mid-sized, locally-owned facilities modernized to a much greater degree than did the major packers. Likewise, small local slaughterhouses operated concurrently with the major packers. This ran contrary to the trend elsewhere, which was that major packers introduced increasing levels of automation and gained near-total production monopolies.²⁹

British Columbia's unique corporate structure emerged, in part, because it was peripheral to the larger political economy of meat-packing in North America, but the industry should not have survived the departure of the Canadian big three in the 1970s. Large, multi-story meat-packing plants that replaced people with machines and monopolized their supply chain were supposed to wipe out regional competitors. This concern is exactly what, in the twentieth century, motivated so much government investigation of the big packers in Canada and the United States. However, the domestic BC meat-packing industry remained competitive within the provincial market. Thus, BC meat-packing represents a paradox: it followed many of the same trajectories of North American meat-packing towards larger, more efficient plants, but it did so at the expense of large, efficient production on a national and/or transnational scale.

²⁸ Wells interview, 2010.

²⁹ Foony Chung, oral history interview with author, Victoria, BC, 28 January 2010; Staley, "Beef Packing Industry in British Columbia," 22; William A. Kerr and S. Monica Ulmer, *The Importance of the Livestock and Meat Processing Industries to Western Growth* (Ottawa: Economic Council of Canada, 1984), Tables 18, 19; Smith et al., *Report Concerning the Meat Packing Industry*, 97; SSCA, *British Columbia Meat Packing Industry*, 21-22, 24.

The unique structure of BC meat-packing plants meant that workers in British Columbia had a very different experience of the mid-century industrial revolution in meat-packing than did workers elsewhere. According to Braverman, mechanization and the division of labour were processes that necessarily changed a human worker's ability to know, or relate to, her/his work and therefore affected it in adverse ways.³⁰ However, in the actual application of machines to the work process, different types of "mechanization" had very different meanings, and the mechanization of tools did not immediately result in the mechanization of people. The inexactness of industrial change allowed BC meat-packing workers to perceive skill in less rigid terms than did workers elsewhere. In 1952, in a Burns Vancouver company newsletter, we read: "Driving a truck, wrapping bacon, or dressing cattle may not be as glamorous as being the master of a ship at sea, but it calls for the same pride of craftsmanship ... [I]t is sure to yield the same pride and satisfaction."³¹ However, it is also notable that this passage focuses on labour on the kill floor and final-stage processing, not meat cutting, since these were the departments that were the most threatened by deskilling. The ongoing prevalence of skill and skill-discourse stands out, but it should be noted that skill was also segregated by production departments that were themselves, not coincidentally, segregated by gender. In some cases, divisions of labour even functioned to insulate workers from the deskilling that was occurring right next to them on the line.

KILL FLOOR BOYS

In some ways, the most dramatic form of automated production in the packing plants took place on the kill floor. Each task in this department involved a separate job for a separate worker, and the animals moved through slaughter and evisceration with assembly-line precision. When I spoke to Jim Wells, who worked several different jobs on the kill floor without ever killing an animal or even coming close to learning the full process, he described the slaughter and evisceration process in a way that closely aligned with Braverman's vision of modern corporate factory labour. In the beef kill, there was a job called "hind leg skinner." After the steer was stunned with a retractable firing pin, someone would shackle it by the left hind leg and a pneumatic lift would hoist it to the ceiling. Another worker cut the steer's throat and let the animal bleed out. The

³⁰ Braverman, *Labor and Monopoly Capital*, 92, 307.

³¹ *Spork Plugs/Burns Shamrock News*, March 1952, LLBC.

hind leg skinner stood on a large table and performed the first cut in hide removal, slicing from the free leg to the bung (anus). Another beef kill floor job was called “beef head work-up.” This worker removed the head (which was only dangling by this point) and used a pneumatic axe to split the skull and gather the brains. Another worker had to perform a job known as “harvest beef tripe.” The stomach and intestines flowed down a chute, and this worker separated the edible offal from the leftover food in the animal’s digestive system. There was movement between jobs on the kill floor, but the line was so long that a single worker could only perform a limited number of tasks.³²

On the kill floor, deskillings were an evident consequence of the successfully automated “disassembly line.” According to Foony Chung, who owned Van Isle Meats north of Victoria, the workers “were just walk-off-the-street really because it didn’t need much training – they did one kind of job more or less.” Van Isle was a relatively small, provincially inspected beef slaughterer; nonetheless, it was semi-automated with overhead rails, splitting saws (a kind of portable band saw), and hydraulic mechanical hide strippers. According to Chung, pork kill was even more automated than beef kill.³³

Yet the extensive division of labour and mechanization on the kill floor could not entirely eliminate skill. Even as Wells described the significant division of labour on the kill floor, he remarked on the skill that these jobs required:

I didn’t learn all of the jobs out there, some of them were quite sophisticated and you really had to know what you were doing, and they were really labour intensive. Probably some of the hardest jobs. On the kill floor, one of the job classifications was called “remove hog tongues.” Well it wasn’t just taking the tongue out of the mouth of the hog. The operation required you to take the tongue out and then everything [else ...]. The rest of the esophagus or throat passage all the way down to the stomach and the intestines, heart, lungs all had to be pulled out as part of that job of removing tongues. The tongue was just the last thing to come out. And you had to keep up, you were the only person who did that job.³⁴

Before the carcass even reached the “remove hog tongues” stage, a slew of workers had already worked on it. Someone had to run the hog up a ramp from the stockyards, someone had to electrocute it, and someone

³² Wells interview, 2010.

³³ Chung interview, 2010.

³⁴ Wells interview, 2010.

else had to bleed it. Then the hog had to go through a scalding tub, followed by the dehairing machine. Another worker shaved the hog, and then it had to be hoisted onto overhead rails before the opening up procedure began. And there were many more tasks to follow before the carcass was ready for the cutters. Despite the narrowness of a job like “remove hog tongues,” it required a skilled hand, and, just as important, workers like Wells recognized this.

BC kill floor workers were not degraded in the way that Braverman theorized or as were kill floor workers in major packing plants in the United States. In the pages of *Spork Plugs* it quickly becomes apparent that these workers were jovial, good-humoured, and regarded as the plant clowns. They called themselves the “killing gang” or the “kill floor boys,” and they distinguished the workplace with their tight camaraderie.³⁵ But still, Braverman would correctly point out that good humour is not the same as power. In fact, when compared to the “knife men” of the cutting department, there was something infantilizing about the way kill floor workers were portrayed, and portrayed themselves, as goofballs.

KNIFE MEN

In the meat-packing disassembly line, the men who cut half and quarter carcasses into roasts, steaks, and other saleable cuts were called “meat cutters.” They also called themselves “butchers” and “knife men,” harkening back to their role in the pre-industrial labour process.³⁶ The meat cutters were the highest paid and most skilled workers in British Columbia’s industrial packinghouses, and they protected their status and labour power by maintaining control of the knowledge of a complex process. Workers took advantage of the owners’ difficulty in automating the butchering process and leveraged their skill to protect a stable, middle-class life.

Meat cutting experienced neither the mechanization nor the division of labour present in slaughtering. There were plenty of new machines, but they often simply introduced motors to hand tools, leaving the execution of the task essentially untouched. Among the first and most prominent electric tools used in meat cutting were the band saw and the delicator.³⁷ Both tools were relatively small and inexpensive, and they were widely used in British Columbia throughout the entire second half

³⁵ *Spork Plugs*, April 1947, June 1953, LLBC.

³⁶ Wells interview, 2010; Commons, “Labor Conditions in Meat Packing,” 4; MacLachlan, *Kill and Chill*, 215–18.

³⁷ Stevenson interview, 2010.

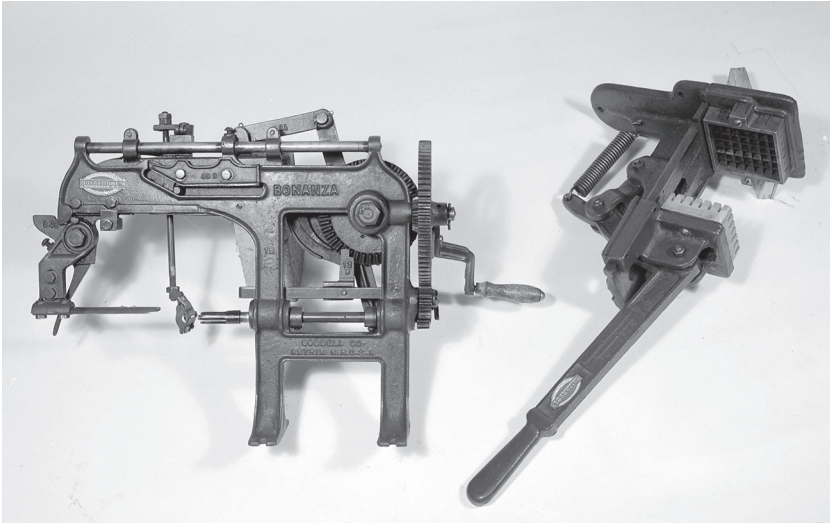

Figure 3. Pictured are a meat grinder and a meat tenderizer from the 1940s. They are simple machines that use levers and hand cranks. The latter was replaced with the delicatour in the second half of the twentieth century. The delicatour was electric, easier to use, and created a better product. Not all mechanization is associated with deskilling or loss of labour power. Jack Lindsay, “Hand Held Meat Grinder and Tenderizer,” ca. 1940s, City of Vancouver Archives, Jack Lindsay Ltd., Photographers Fonds, CVA 1184-3310.

of the twentieth century. The band saw is a stationary power cutter that runs a looped saw blade around an electric motor. All manner of cuts could be performed on the band saw, but it was initially used mostly for primary breakdown (the separation of carcasses into parts). The delicatour ran a bladed cylinder for making cutlets. Neither of these machines was automated. In fact, neither machine changed the philosophy behind the hand-crank machines they replaced. This type of mechanization did not result in deskilling because the machines did not preclude workers from understanding the operation at hand.³⁸

And even then, meat cutters continued to rely primarily on the traditional tools of the trade – knives. The knife was the single most important tool in any meat-processing plant. The cuts on an animal were extremely

³⁸ Many of the machines used in British Columbia in the first half of the twentieth century were hand-crank tools, and the new tools simply added electric motors to perform the same movements. See, for example, Jack Lindsay, “Butchers’ Machine for Tying Roasts and Other Cuts of Meat,” ca. 1940s, CVA, Jack Lindsay Ltd., Photographers Fonds (hereafter JLF), Add. MSS. 1184; Lindsay, “Hand-Held Meat Grinder and Tenderizer,” ca. 1940s, CVA, JLF, Add. MSS. 1184; Lindsay, “Meat Hooks, Spatulas and Squeegies,” ca. 1940s, CVA, JLF, Add. MSS. 1184; Berger and Carter Company, *Section No. E-18 of the General Catalog: Machinery Supplies and Equipment for Fish Canning, Meat Packing and Fertilizer Plants* (San Francisco: Sunset Publishing House, 1917), SPAM250.A, UBC Special Collections.

complicated, and until late in the century no automated machine could perform these tasks. Meat cutters in both small shops and large packing plants had to learn the cuts and perform them with the same basic hand tools as had been used before. According to Braverman, pre-mechanized craftwork included full knowledge of the science and technologies of the work process and a close relationship between manual labour and mental labour. For Braverman, skill includes control of the tools, and it was this skill that underwrote workers' power in the pre-industrial labour process.

In many larger operations, meat cutters did not actually maintain control of their knives since the company furnished the tools and, in collective bargaining agreements, stipulated: "[they] shall remain company property." However, as symbolic capital, the knives were (albeit indirectly) under the workers' control. Every major collective bargaining agreement contained an article describing exactly what tools – including "knives, steels, whetstones, triers, meat trimmer hooks, scabbards, and over-hauling hooks" – the company had to provide and another article ensuring that workers be given time to perform their own knife sharpening and maintenance during their shift.³⁹ Knives were a very basic technology, but they were the defining technology of the job, and each contract ensured that they would remain so.⁴⁰

Meat cutting was certainly labour-intensive work, but it was also mental work. Don Cunningham was a meat cutter at a small, independent butcher shop on Saltspring Island in the 1960s, and when I spoke with him, he could still describe with precision the exact process of breaking down a carcass into primal cuts.⁴¹ Obviously, Cunningham learned the whole craft as there was virtually no division of labour at his workplace. Interestingly, Jim Wells, who worked at Intercontinental Packers Vancouver, the single largest and most modern packing plant in British Columbia, did the same thing, and he described exactly which bones he cut and in which direction he moved the knife.⁴² In theory, different types of facilities were supposed to perform only a certain amount of the processing, but it did not work out that way. Lloyd Stevenson worked at a Victoria secondary processing and distribution plant in the 1970s, but it still received beef and hogs in full carcasses that had to be processed down

³⁹ British Columbia Labour Relations Branch Collective Bargaining Agreements, 1946-71, BCA, GR 1430, file 42, p. 44, reel B00617, Canada Packers Ltd., Canadian Food and Allied Workers Local P162, 1969.

⁴⁰ MacLachlan, *Kill and Chill*, 218.

⁴¹ Don Cunningham, oral history interview with author, Saltspring Island, BC, 23 January 2010.

⁴² Wells interview, 2010.



Figure 4. Three men deboning and portioning meat by hand at the Burns Vancouver plant. They are all doing the same job with the same tools to the same hanging carcass sides with no assembly-line style division of labour. Jack Lindsay, “Meat cutters at work at Burns’ Meats,” ca. 1940-1948, City of Vancouver Archives, Jack Lindsay Ltd., Photographers Fonds, CVA 1184-1788.

to restaurant ready-to-cook portions.⁴³ Jim Moir and Norm Watling, who worked at smaller butcher shops, also described how they received sides and quarters well after the introduction of boxed beef programs in the late 1970s.⁴⁴

The remarkable similarity between meat cutters in industrial packing-houses and traditional local butchers was largely a product of the limited division of labour in meat-cutting departments. Jim Wells explained both the difficulty of the job and how imperative it was for someone to understand the whole process:

Jim Wells: About a half a year into my job in the shipping cooler, I really wanted to become a knife man. I wanted to learn how to do the jobs associated with using a knife, but there are all sorts of different departments and levels of using a knife. I mean, you don’t turn a guy loose on a carcass of grade A beef and say, “well you just go and attack

⁴³ Stevenson interview, 2010.

⁴⁴ James W. Moir, oral history interview with author, Vancouver, BC, 16 February 2010; Watling interview.

that thing, and you cut it up the way you think it should be done.” There’s a learning process, of course. So I wanted to learn how to use a knife and become an all around butcher.

Author: Was it the allure of the trade?

Jim Wells: No, I didn’t have any motivation or thoughts about, you know, learning how to be the grand alley pooh bah knife wizard or anything like that or one day maybe I’ll be a professor of meat cutting at the University of Victoria. It was nothing like that, it was just I wanted to learn that job. And in those days, the only chain work, like assembly-line type work, conveyor-belt type work, that was done on an animal was on the kill floor during the eviscerating process. But after that process it was an individual working on a quarter of beef or a half a packer hog or whatever the case may be. It wasn’t doing *a* job on a boning table, where all you did all day long was take out the H bone in a ham, and the next guy, he took the skin off, and the next guy, he took fat off, and so on and so forth. When I got my start in the knife part of doing the job, you did the whole operation. You could go, and you could learn all the beef cuts. So I wanted to be a knife man, and during the course of time between shipping ... and getting my first knife job, I worked in a lot of different areas.⁴⁵

Wells explained that the company finally gave him his first cutting job on the night shift, but it transferred him to the day shift almost immediately. The reason for his transfer confirms the truth of what he describes above: He had not yet been properly trained, and on the night shift a single worker could end up running the whole department.

The closeness of craft butchers and industrial meat cutters posed problems for organized labour and the axiom that craft and industrial workers were different and had different needs. In 1937, in the interest of all butchers and meat cutters in Vancouver and the surrounding area, the workers at the Burns Vancouver plant started a union. That union inadvertently broke union organizing regulations because it recruited lots of small butchers who were, themselves, employers of labour.⁴⁶ After that, workers were organized separately by the rival Amalgamated Meat Cutters and Butcher Workmen of North America (AFL) and United Packinghouse Workers of America (CIO); however, as early as 1953, the two unions were coordinating collective bargaining, and they

⁴⁵ Wells interview, 2010.

⁴⁶ Commission on the Labour Dispute at Burns and Company Limited, 1937, BCA, GR0912.

formally merged in 1968. This merger was part of a larger pattern following the creation of the AFL-CIO in 1955, but it was also part of a much longer process that involved both sides recognizing that all types of meat-processing workers shared similar experiences and belonged in the same union.

Despite the mechanization and automation occurring elsewhere in the workplace, many meat-processing workers continued to view production as a craft. They developed a way of viewing their work that enabled them to take aspects of craftwork and adapt them to their industrial capitalist workplace. These male workers recognized and valued the skill associated with each other's work, and they found that they could be both industrial workers *and* skilled workers. Lloyd Stevenson described the workplace: "Blue collar, labourer. You can say with that too that there always is a trade involved, butcher, baker, candlestick maker. Yeah, it's a trade, it's a union, a trade."⁴⁷ Despite changes in the workplace, it was clear to the workers that they were performing work of which they could be proud. And this was important because management apparently bought into this way of viewing meat cutting, paying out some of the highest wages offered by any industrial employer in Canada. But only men had access to this workplace pride and its impressive wages.

SAUSAGE GIRLS

Large-scale mechanization in British Columbia's meat-processing facilities was concentrated in certain departments that were, not coincidentally, segregated by gender. Take, for example, Burns Vancouver in the mid-twentieth century: in 1948, the plant installed a new wiener-banding machine; in 1954, the sausage kitchen got a new casing machine; in 1955, the plant installed a new ham press, a ham stuffing machine, and a bacon curing machine; and, in 1957, the plant put in a conveyored bacon-wrapping station.⁴⁸ Clearly, most mechanization occurred in the final-stage processing departments. Sausage grinders, patty makers, deli meat slicers, packaging machines, and curing machines still required human machine operators, but they effectively automated the tasks for which they were created.

The deskilling effects of these machines did not raise much concern because the skills they replaced did not have the value or cultural cachet of knife skills. For example, one of the bigger and more automated machines available was the meat grinder and patty maker. Norm Watling, who

⁴⁷ Stevenson interview, 2010.

⁴⁸ *Spork Plugs/Burns Shamrock News*, March 1948, July 1954, March 1955, December 1955, February 1957, LLBC.

mostly worked in smaller shops, told me that he never saw one of these machines until the 1980s; instead, “to make the meat patties we used to take PVC pipe, jam it full of ground beef, throw it in the freezer, and then run it under warm water, the frozen beef would come out, and just cut it on the band saw.”⁴⁹ It was a clever process for making hamburger patties, but not one that would be sorely missed. Nonetheless, some of these machines did seize intellectual control from the workers. For example, during the second half of the twentieth century, BC processors started using a new type of smokehouse that smoked meat on continuous, timed conveyors and used electrically charged smoke to minimize wasted energy.⁵⁰ The job of smoking had required an exacting knowledge of the time and amount of smoke it took to cure various meats, but the new machine decreased both the amount of labour and the knowledge needed for smoking meat.

Sometimes machines simply entailed changing skills, but other times they really did deskill meat production because they moved technological knowledge to a non-production worker. A good example is the Cryovac, which began operating in British Columbia in the 1960s. This is a machine that as an inexperienced college student, I successfully operated in the summers of 2008 and 2009. The Cryovac vacuum-packed meat in plastic bags, and it was a welcome technological innovation for meat-processing companies since it cut down on the amount of labour needed to hand-wrap meat properly. According to Lloyd Stevenson, the only two machines in Victoria in the 1970s were German-made, and: “when they busted down ... we had to phone the university and get some German engineer to fix it because they were quite complicated.”⁵¹ The Cryovac effectively marginalized wrapping workers’ traditional skills for preserving meat; meanwhile, its complexity prevented production workers from learning any new skills. At first glance it might seem trivial, but there is certainly power in controlling the wrapping process. In the wrapping department in which I worked, one customer continued to insist on butcher-paper-wrapped products, and the worker who could do this job justifiably made more money than did those of us who were on the machine all day.⁵²

The other important part of my personal anecdote about the Cryovac is that I was only there because I was a temporary worker and a soft-

⁴⁹ Watling interview, 2010.

⁵⁰ Wells interview, 2010; Rennie, *Growth and Development*, 63.

⁵¹ Stevenson interview, 2010.

⁵² See also Addie Wyatt, “An Injury to One Is an Injury to All: Addie Wyatt Remembers the Packinghouse Workers Union,” *Labor’s Heritage* 12 (2003): 29.

palmed student – otherwise, this job was mostly women’s work. Gender determined the kinds of jobs that men and women in BC meat processing would normally perform. Slaughter, evisceration, and meat cutting were all men’s work.⁵³ When women entered the packing plants in the 1940s they sometimes performed these jobs, but by the 1960s the division of labour was strongly re-entrenched. I asked Lloyd Stevenson, who seemed to know every person in the industry in Victoria, about women in British Columbia’s meat-packing facilities, and he could remember a few – but only very few:

Stevenson: The only – No, we had no women in Gainers right up until 1990. I think the only girls they had working was at Alberta Meat ... and they had two girls there that were boning pork legs and veal and making cutlets. That was their job, and that’s the only two girls I know of in Victoria ... Gainers had nobody, G&F didn’t have anybody. But it’s – women still, what have we got now? We’ve got Mags and that’s about it. One girl. The only cutter I know of even after all these years. In Victoria I mean, I think some of the big plants back in Vancouver had a lot of women cutters, and ... but no, they were always packaging. It was always in the packaging area.

Author: Did they do things like sausages?

Stevenson: Yeah, they’d make the sausages, but then that’s a secondary cutting. It’s just the grinding and the packaging. No, we never had any. I think Safeway may have had a couple of girl cutters at one time. I don’t know what shies them away, it’s not heavy work anymore, but I think the cold and the hands and the – well it’s not an attractive job for a woman.⁵⁴

Stevenson’s recollections confirm that most women in the industry were concentrated in packaging and final-stage processing. Furthermore, those tasks, and therefore those women, were barely seen as part of the meat-packing job (or craft). Obviously, there were some exceptions, like Cathy Lathange, who became Foony Chung’s best veal hide skinner, or the few women whom Norm Watling trained as cutters at smaller retail stores, but for the most part women did not work in these areas of meat production.⁵⁵ I believe that my own canvas for oral history interviews

⁵³ Cynthia Loch-Drake argues that this led to a hyper-masculinity among Edmonton’s meat-packing workers. See Loch-Drake, “Special Breed,” 134.

⁵⁴ Stevenson interview, 2010.

⁵⁵ Don Coltman and Steffens Colmer, “Angela Gedak Skinning Beef at Pacific Meat Company,” CVA, Williams Bros. Photographers Collection, Add. MSS. 1545, 1943; Chung interview, 2010; Watling interview, 2010.

failed to solicit any responses from women who worked in meat-packing because I focused too heavily on identifying butchers and meat cutters: I did not mention grinding, sausage making, or canning in my public notices because, at that time, I shared the understanding that these were somehow peripheral to the job of meat-packing. When I started this project, I did not even think of *myself* as having been a part of it since I had just worked the Cryovac.

Final-stage processing, in packing-house gender norms, was definitely women's work. In contrast to the "kill floor boys" the grinding departments had monikers like the "sausage kitchen girls" and the "ham room girls."⁵⁶ This division had little to do with the actual tasks or difficulty of the labour as pickling could be heavier and more dangerous work than wielding a knife.⁵⁷ Rather, the division was based on ideas about the products themselves, with cuts like steaks being understood as masculine and processed meat being understood as feminine (because inexpensive, convenience food was family food).⁵⁸

Normally, there was a lot of movement between departments in meat-packing plants, but male workers rarely, if ever, found themselves at the women's end of the line. Sometimes, in "plant personality" features and retirement announcements, *Spork Plugs* and *Shamrock News* took the opportunity to recap workers' careers with the Burns Vancouver plant, and the gender wall was obvious. Stan Gates worked in the pork-cutting department, on the kill floor, and in the beef coolers before becoming the beef manager. Stan Keefer worked both on the kill floor and in the pork-cutting department. Alexander "Mac" MacDonald worked in the freezers and "all jobs" in the beef coolers before becoming the head meat cutter. According to a 1977 BC government report: "job definition virtually does not exist in the industry. Under present contracts an employee is required to do work which he is assigned as long as he is paid his wage classification or any higher applicable rate." But, as you can see, none of these men worked in canning, grinding, smoking, or other machine-automated processing departments.⁵⁹

⁵⁶ *Spork Plugs*, December 1947, June 1948, October 1953, LLBC.

⁵⁷ Addie Wyatt recalled that, when women finally made it onto the hog kill floor, they found the jobs easier than some they had been confined to before. See Wyatt, "An Injury to One," 30.

⁵⁸ Roger Horowitz, "'Where Men Will Not Work': Gender, Power, Space, and the Sexual Division of Labor in America's Meatpacking Industry, 1890-1990," *Technology and Culture* 38 (January 1997): 189; MacLachlan, *Kill and Chill*, 218; Phillips and Taylor, "Sex and Skill," 79.

⁵⁹ *Spork Plugs/Burns Shamrock News*, Christmas 1949, March 1952, December 1955, LLBC; SSCA, *British Columbia Meat Packing Industry*, 10.

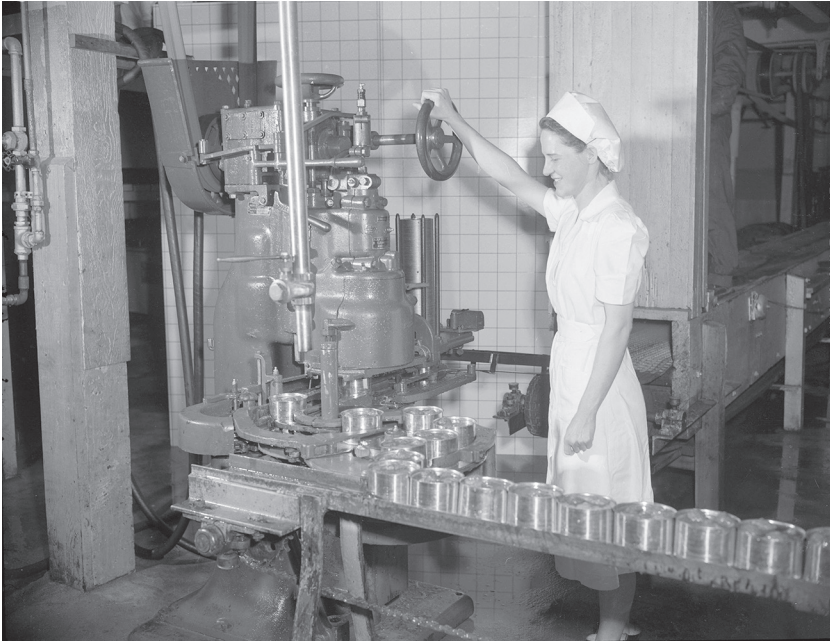

Figure 5. A woman worker operates a semi-automated machine to seal cans of meat at Hedlund's Fancy Sausage Ltd. in Vancouver, ca. 1947. Jack Lindsay, "Woman operating machine to seal cans of Hedlund's Ltd. meat products," ca. 1947, Jack Lindsay Ltd., City of Vancouver Archives, Photographers Fonds, 1184-3554.

This meant that it was women who worked in the most mechanized and automated part of meat-packing, and that it was women who bore the brunt of the consequences of these processes. *Shamrock News* lauded this development, calling it "streamlining with curves," but these jobs took a serious toll on workers' livelihoods and bodies.⁶⁰ In 1957, Burns Vancouver installed a new bacon-portioning machine that semi-automatically wrapped bacon at "speeds up to 50 packages per minute" using multidirectional conveyors and at least six female workers.⁶¹ I have some experience in wrapping, and that sounds overwhelmingly fast to me. Historian Roger Horowitz reminds us that the types of injuries women suffered in the packinghouses has been grossly underappreciated right up to the present as employers either neglect or refuse to catalogue repetitive motion disorders such as carpal tunnel syndrome.⁶² The fast-paced hand movements needed to package bacon, make sausages, or can wieners wore away at workers' bodies and ultimately caused more women to take

⁶⁰ *Burns Shamrock News*, April 1958, LLBC.

⁶¹ *Burns Shamrock News*, February 1957, LLBC.

⁶² Horowitz, "That Was a Dirty Job," 15, 22.

time off work than did the more serious but less frequent lacerations and amputations experienced by male workers. Further, women could expect significantly lower pay for these dangerous jobs. For example, the job category with the lowest pay rate in the 1970 contract between the Canadian Food and Allied Workers and Gainers Ltd. was, literally, "Machine Operator (Female)."⁶³

Interestingly, the connection between women and automation was stronger in British Columbia, and in Canada generally, than it was in major American packing plants. Since managers believed that machine operation required skill, men filled management and overseer positions in the grinding departments in the United States.⁶⁴ No evidence suggests that this was the case in British Columbia, and photographs in *Spork Plugs* and *Shamrock News* clearly depict women running machinery.⁶⁵ In fact, when Hedlund's Fancy Meats tried to recruit workers in the 1950s to the grinding position, they claimed that final-stage processing required "skilled girls."⁶⁶ In context, this utterance and the apparent willingness of employers to let women operate machines reflects a notable upskilling of women in these departments compared to elsewhere in North America, but it also further separates craft-like processes and machine processes by allowing the latter to become fully feminized. Perhaps this tenuous – but meaningful – element of skill in mechanized processing rested on the ongoing whiteness of the job. Most of these women were white, and they seem not to have competed with male and female workers of colour, as was common elsewhere in North America.⁶⁷

⁶³ "BC Ministry of Labour – Collective Agreements 1965-1975," BCA, GR1563, box 1, file 45.

⁶⁴ Horowitz, "Where Men Will Not Work," 188, 209.

⁶⁵ See, for example, the new sausage-casing machine featured in *Burns Shamrock News*, July 1954, LLBC.

⁶⁶ "The Story of Canning Specialty Meat Products," LLBC, Department of Education, Division of Educational and Vocational Guidance, BC Occupations Series, ca. 1952.

⁶⁷ In the United States, early deskilling was accomplished mostly through the exploitation of black workers, both men and women (Horowitz, *Negro and White*, 1997; Halpern, *Down on the Killing Floor*, 1997). Likewise, Cynthia Loch-Drake's study of Edmonton's packinghouses demonstrates that deskilling coincided with a wave of immigration that brought in people of colour and that led to a racialized-gendered understanding of job categories (Loch-Drake, "Special Breed," 138). Based on photographs and a lack of evidence of racial conflict, it seems that these departments, gendered male or female, remained whiter in British Columbia than elsewhere. Perhaps this was due, in part, to the fact that, in British Columbia, seafood processing already attracted significant Asian and Aboriginal labour, both male and female, creating a racial divide more according to species more than skill. See Alicia Muszynski, *Cheap Wage Labour: Race and Gender in the Fisheries of British Columbia* (Montreal and Kingston: McGill-Queen's University Press, 1996). It is important to remember that race and gender were never absolute predictors of job category anywhere in North America, and their influence waxed and waned over time. For example, when new corporate meat packers built plants in the American west in the 1970s and 1980s, they used rural white labour to further deskilling

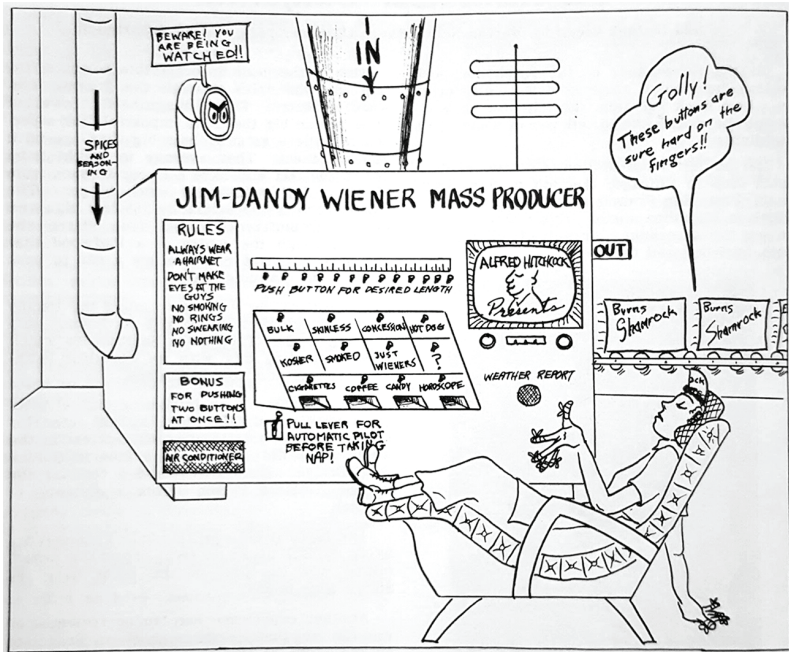

Figure 6. The close association of women and automated production was mostly a joke to managers and male workers. While this cartoon from *Burns Shamrock News* belittles the types of injuries women faced, it does allude to the serious threat that automation, with its concomitant surveillance and deskilling, posed to workers' power. *Burns Shamrock News*, June 1957, Legislative Library of British Columbia.

In 1957, *Burns Shamrock News* printed a cartoon, drawn in Edmonton, depicting the company's perspective on women and automation. In the drawing a machine called the "Jim-Dandy Wiener Mass Producer" automatically forms and packages the product while a lazy woman complains about the hard work involved in her job pushing buttons.⁶⁸ Obviously, this machine is imaginary, but the cartoon reveals the association between women and mechanization. In this context, machines require no skill and, since they do no work, operators have no claim to labour power. Gender segregation and the ongoing masculine, productivist conception of labour value had, and still have, disappointing consequences for women's ability to participate in and benefit from the labour movement.⁶⁹ The uncomfortable corollary of this is that they both served working men very well.

because this particular demographic had an aversion to organized labour (Fink, "Farm Boys," 2002).

⁶⁸ *Burns Shamrock News*, June 1957, LLBC.

⁶⁹ Productivism is the belief that economic growth is both good and necessary, and even an end in itself. Productivist hegemony leads to the belief that *productive work* – meaning waged labour – defines self and social worth. See Anthony Giddens, *Beyond Left and Right: The*

The gendered division of labour actually counteracted the usual effect of the division of labour by enabling workers to forget that this division was not natural. Deskilling decreased since grinding did not count as a real part of meat processing. This division prevented women from seeing their work as a craft, while it enabled men to do precisely this. Men did not have to see this gendered division as a loss of their ability to grind (which is what it was) since it redefined grinding as being inherently outside the rest of the meat-packing process. In fact, the men whom I interviewed for this project had very little to say about the changes happening in tertiary processing departments because gender segregation blinded them to this break in the full production task. Paradoxically, the feminization of the rump end of meat processing actually enabled male workers to continue to see their work as a craft.

CONCLUSION

Did British Columbia's workers resist the dominant corporate trends in meat-packing that transformed the food supply and degraded skilled labour across North America? Census figures reveal that more men worked in meat cutting (the most skilled part of the labour process) in British Columbia than anywhere else in Canada. And oral history interviews and company newspapers reveal that, in this province, meat cutting remained a particularly skilled and respected trade.⁷⁰ This certainly created in BC workers a strong sense that their work was a craft and something to be proud of, but does it explain the unlikely continuation of the BC meat-packing industry in the face of massive transformations at the national and transnational levels – transformations that so clearly threatened to eliminate it? If Braverman's analysis is correct, then there is an association between workers' skill (which is fundamentally a shorthand for their ability to know and control the labour process) and their ability to demand good wages and a safe and healthy work environment. In the end, however, meat cutters' ongoing use of knives and so on only partially staved off the force of an increasingly amalgamated Canadian and American system of corporate behemoths. The BC meat-packing industry survived, but, after the exodus of the big three in the 1960s, it did not flourish. And today kill floors have all but disappeared

Future of Radical Politics (Stanford, CA: Stanford University Press, 1994); and Tim Jackson, *Prosperity without Growth: Economics for a Finite Planet* (New York: Earthscan, 2009).

⁷⁰ The Canadian census divided all meat-processing workers into "meat cutters" and "canners, curers, packers," with the former comprising a disproportionately high percentage of the total in British Columbia. See the Occupations tables of the *Censuses of Canada, 1921-91*.

as meat comes into the province broken down in boxes from as near as Alberta and as far as Australia.

The case of the BC meat-packing industry reveals an uncomfortable reality about gender segregation in the workplace. This was, of course, created by management, but workers accepted it as a natural division. In British Columbia, gender obscured automation and mechanization and ultimately enabled male workers to continue to make status claims based on skill. We have to respect the place that meat cutters made for themselves within a hostile corporate environment, but the exclusion of women from meat cutting and the exclusion of men from final-stage processing masked the industrial transformations that were taking place. While discourses of skill can have a valuable role in worker resistance, as demonstrated by the success of meat cutters, they are flawed tools when they reinforce gender divisions. Male workers benefited from gender segregation in the short term because it protected them from automation, but women were workers too, and, in the long term, all workers suffered from the lack of solidarity that such segregation fomented.

The reign of the knife men did eventually end in British Columbia. The men with whom I spoke who worked in British Columbia's meat-processing industry in the mid-twentieth century – some of whom are still working – often pointed out that meat cutters today just cannot do what they did. Don Bold, a meat cutter and (later) owner of a meat wholesale business, told me:

If you were to walk into a butcher shop now, into a meat-cutting area, say Thrifty's [Thrifty Foods] or Fairway, Mr. Grocer, and threw a front and hind quarter on the block and said, "cut that up," they'd look at you like you're nuts. "What am I supposed to do with that?" They wouldn't have a clue how to break it down. 'Cause all they ever saw is all the primal cuts broke down to Cryovac in a box.⁷¹

Most of my informants found this a little sad; some found it a little funny: no one thought very highly of these unskilled workers. In the 1990s, meat cutters stopped taking the three-year apprenticeship that had been normal and necessary before, and very few meat-packing workers are still in a union.⁷² Further, recently developed technology can use advanced computer software, three-dimension scanning, and lasers to accurately portion and trim steaks from large boneless cuts, and at least one such machine is now delivering meat to British Columbia without touching a butcher's hands. At the same time, we ought not to glorify the industrial-craftwork past unequivocally. As Jim Wells told me: "That's hard work in a packing plant, boy. Brutal work, dirty, filthy, stinking, dangerous, hurtful work."⁷³

⁷¹ Don Bold, oral history interview with author, Victoria, BC, 29 January 2010. See also Chung interview, 2010.

⁷² Watling interview, 2010; Stevenson interview, 2010.

⁷³ Wells interview, 2010.

ORAL HISTORY INTERVIEWS

| NAME | DATE, DD/ MM/ YY | LOCATION/TYPE OF INTERVIEW | ROLE WITHIN THE BC MEAT-PACKING IN- DUSTRY | RELATIONSHIP TO INTERVIEWER |
|-------------------|---------------------------|--|--|--|
| Don Bold | 29/01/10 | Victoria, BC | Butcher and meat cutter in Victoria in 1970s, owner of B&C Meats ca. 2008. | Owner of firm at which interviewer was an employee |
| Foony Chung | 28/01/10 | Victoria, BC | Owner of Van Isle Meats, a provincially inspected slaughter facility on Vancouver Island, ca. 1960s to 1990s. | None |
| Don Cunningham* | 23/01/10 | Saltspring Island, BC | Butcher in a small shop on Saltspring Island, BC, 1963 to 1970. | None |
| James Currie* | 15/01/10 | Correspondence by e-mail | Letter concerned Currie's uncle, Wilho Olavi Maki, who owned and operated a slaughter facility in Nanaimo, BC, ca. 1930s-70s. | None |
| Dr. Abraham Kidd* | 21/01/10 | Victoria, BC | Veterinarian, held positions as livestock commissioner, chief veterinary inspector, and commissioner of fur farms for the province of British Columbia, ca. 1947-78. | None |
| James W. Moir | 16/02/10 | Telephone interview from Vancouver, BC | Butcher and meat cutter in Duncan and Victoria, ca. 1962-70s. | None |
| Lloyd Stevenson* | 28/12/09 | Victoria, BC | Meat cutter in Victoria, 1961-present (at time of interview) | Former co-worker |
| Norm Watling* | 11/03/10 | Victoria, BC | Butcher and meat cutter in Victoria, 1959-2009. | Former co-worker |
| Jim Wells | 06/02/10 | New Westminster, BC | Packinghouse worker and meat cutter at Intercontinental Packers, Packinghouse union organizer for UPWA and UFCW Local 1518, 1964-2008. | None |

Sources: The author collected oral history interviews by: (1) contacting former co-workers and other personal contacts at the firm at which he worked; (2) contacting the United Food and Commercial Workers Union Local 1518; (3) posting flyers in libraries and seniors' centres in Victoria and the Fraser Valley; (4) posting notices in Victoria's *Monday Magazine* and *Times Colonist* newspaper. Special thanks to *Times Colonist* editor Dave Obee, who wrote an opinion piece on my project. See Dave Obee, "Preserving a Meaty People's History," *Times Colonist*, 10 January 2010. Oral history interviews were conducted with approval from the Human Research Ethics Board of the University of Victoria, and all informants declined the offer of a pseudonym.

* Designates interviewees who wished to make their interviews public. Transcripts are available in the University of Victoria Library Special Collections in "Knife Men: Craft and Industrial Labour in British Columbia's Meat Processing Industry, 1947-79," call no. TS1970 P38 20100.